

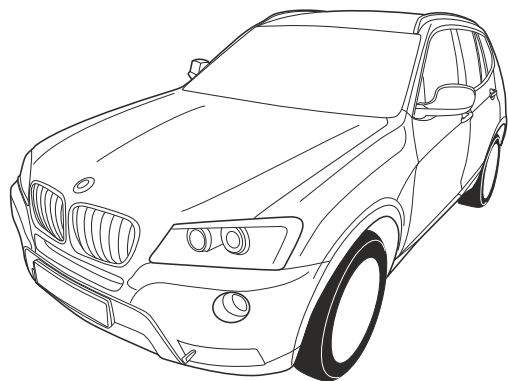

Ryder Towing Equipment Ltd

Vehicle-Specific Towing Electrical Kits TF2351BMW



- BMW X3 2010>2017 (F25)**
- BMW X5 2006>2013 / 2013> (E70)(F15)**
- BMW X6 2008>2014 / 2014> (E71)(F16)**

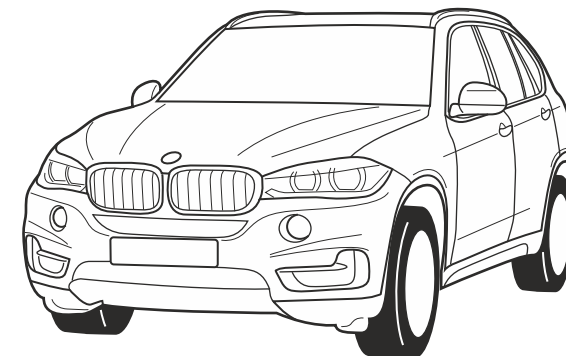

Caravan Auxiliary (12S) function is built in

Installation is simple and quick - no need to “take the vehicle apart”.

High-quality connections throughout are easy and uncomplicated

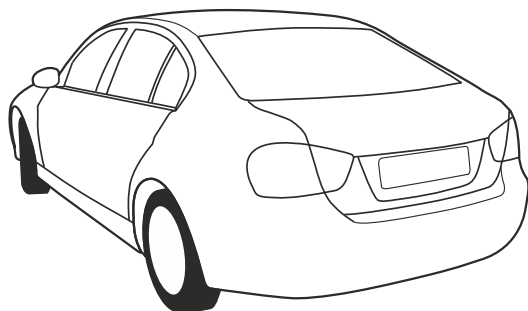

Contents

Pages 2,3,4	Cable routing, CAN & power connections
Page 5	Detail of power and caravan auxiliary connections
Page 6	Kit components
Page 7	CANbus connections
Page 8	Socket assemblies
Page 9	Testing and coding

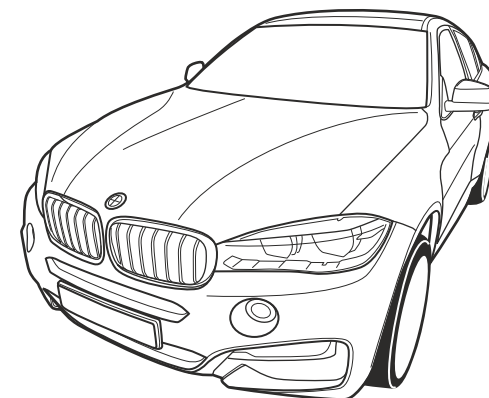

Fully compatible with vehicle management systems to activate all vehicle safety features
Type approved and built to OEM standards
Instructions are easy to follow

Ryder Towing

Quality – Service – Innovation

TF2351BMW

Cable routing, CAN & power connections for BMW X3 (F25)

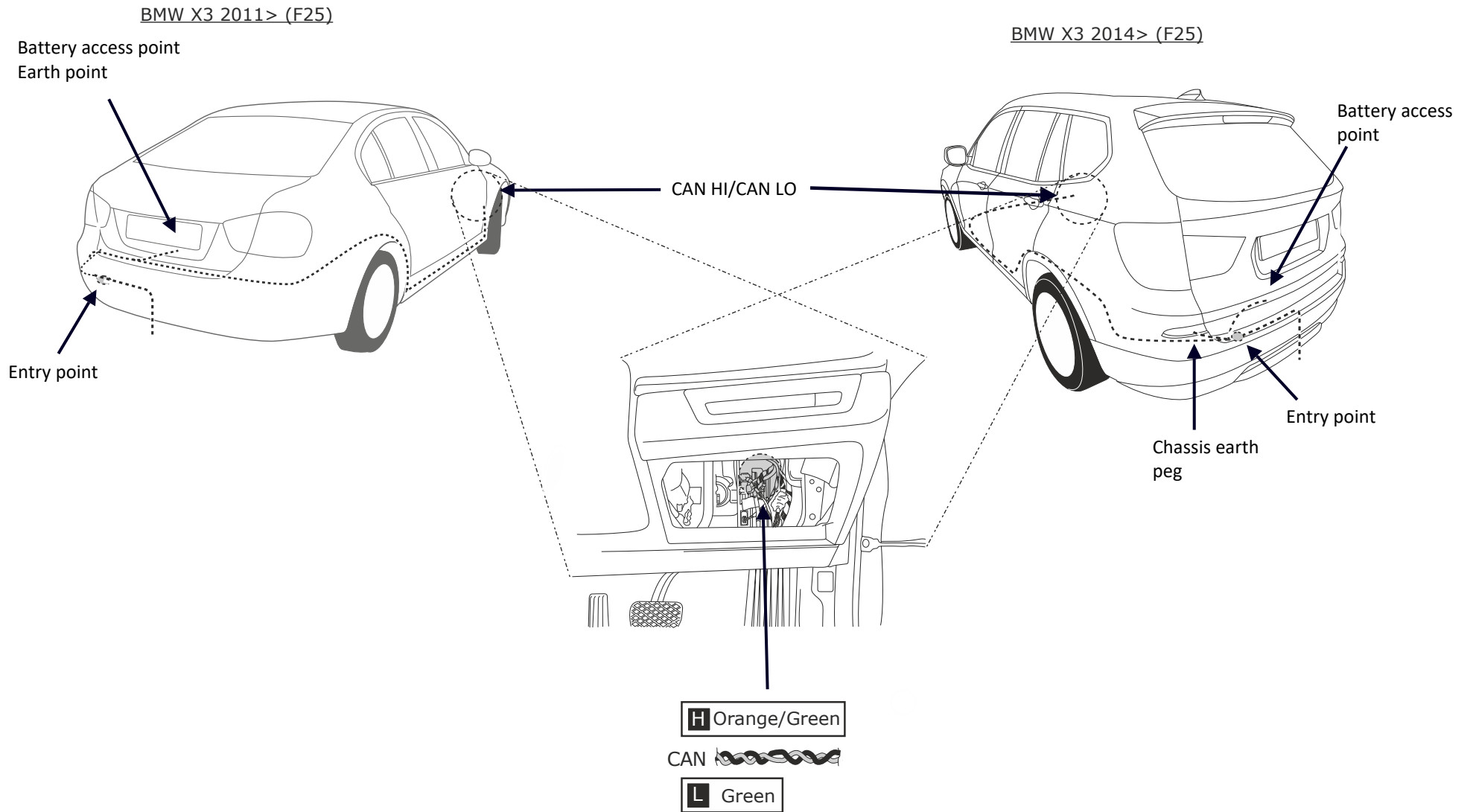

TF2351BMW

Cable routing, CAN & power connections for BMW X5 (E70)(F15)

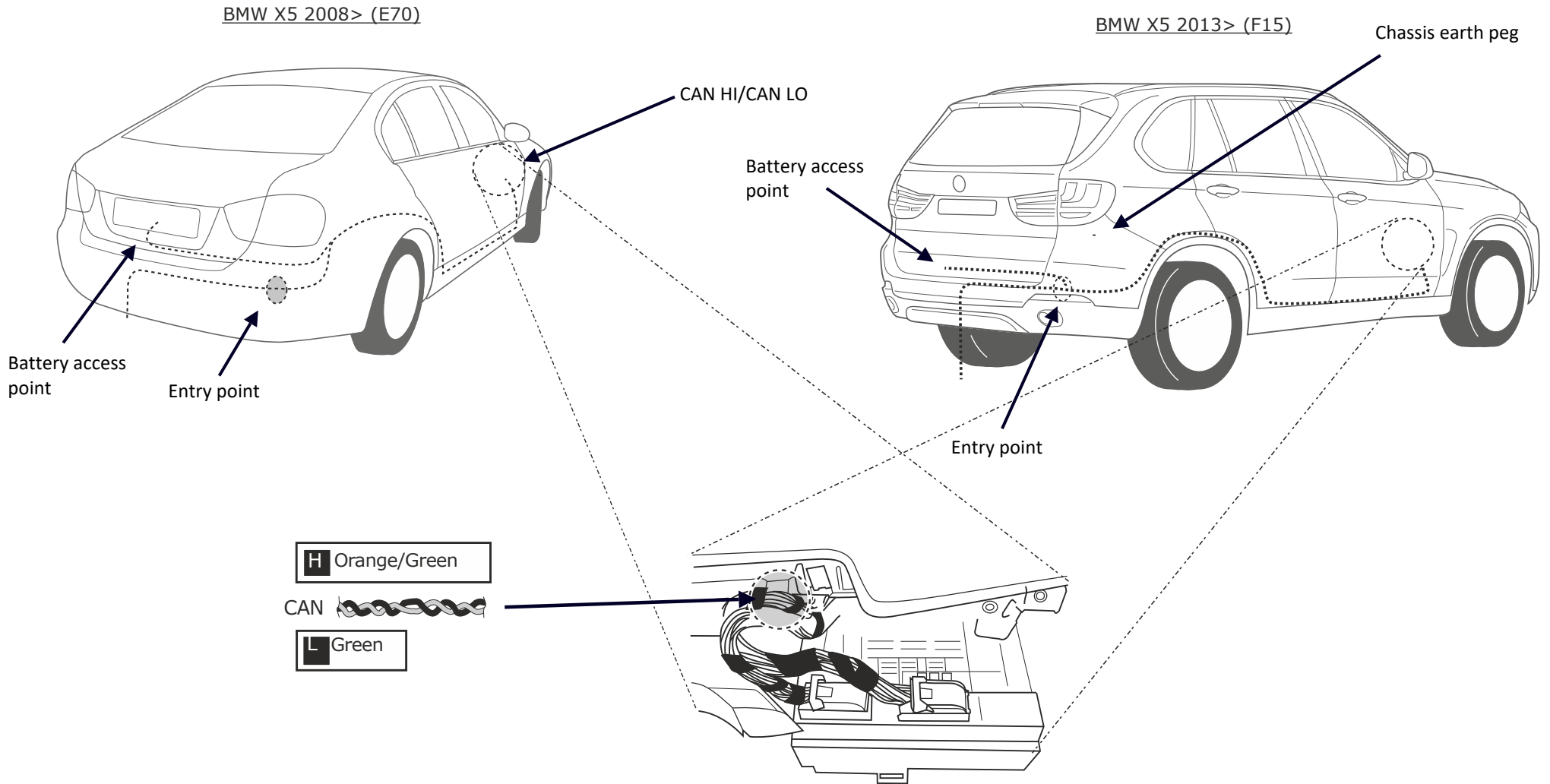

TF2351BMW

Cable routing, CAN & power connections for BMW X6 (E71)(F16)

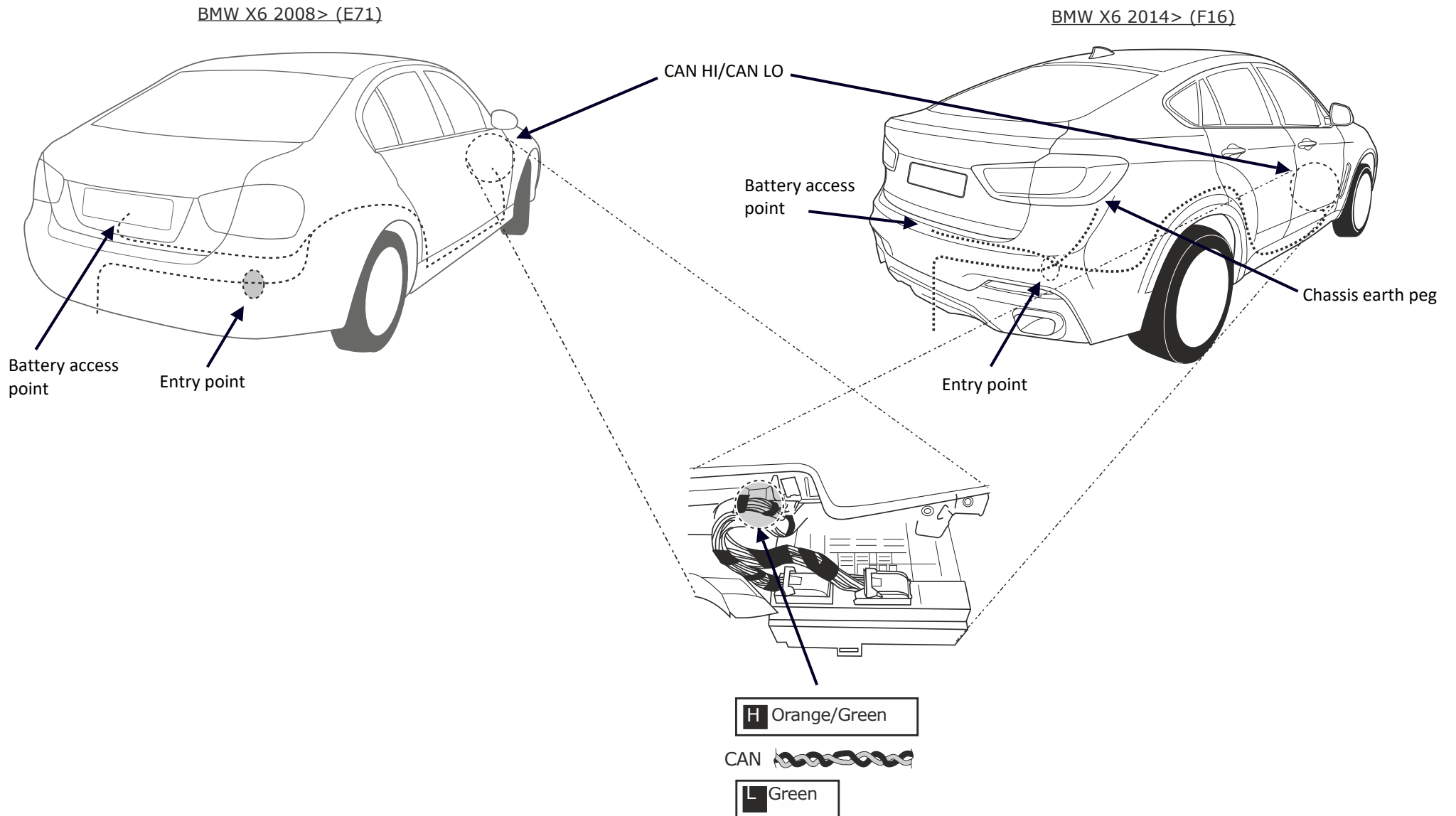

TF2351BMW

Power and Caravan Auxiliary Detailed Connections

Module loom detail

1	LH FLASHER	YELLOW	Socket yellow 1
2	CHASSIS	WHITE	Ring terminal to chassis
3			
4	C2	PINK	Buzzer
5	CAN LO	BLACK	Twisted pair to CAN
6	CAN HI	RED	
7	RH FLASHER	GREEN	Socket green 4
8	RH TAIL	BROWN	Socket brown 5
9	STOPS	RED	Socket red 6
10	LH TAIL	BLACK	Socket black 7
11	REVERSE	YELLOW/WHITE	13-pin 8 or 12S 1
12	FOG	BLUE	Socket Blue 2

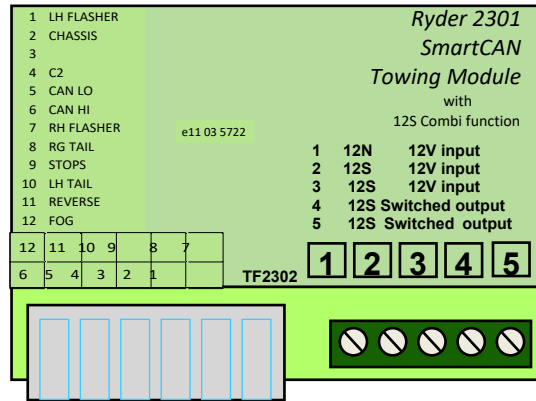

- 1 12N 12V input The fused input for the road lights (15 amps)
- 2 12S 12V input One of two connected inputs for the caravan auxiliary function
- 3 12S 12V input Second of two connected inputs for the caravan auxiliary function. Use this for the unswitched caravan output
- 4 12S Switched Output Two switched outputs for the caravan fridge.
- 5 12S Switched output Having two outputs reduces voltage drop

The caravan auxiliary supply is controlled by the CAN system, using the engine revs. This means its function is not impaired if the vehicle has "Smart" charging.

USE ONE OR TWO POWER TAPS TO TAKE POWER FROM THE FUSEBOX IN THE BOOT OF THE CAR



USE ONE POWER TAP FOR A (12N) INSTALLATION (7 OR 13-PIN)
 USE TWO FOR A DOUBLE (12N+12S) INSTALLATION (TWIN 7 OR 13-PIN)
 FUSE THE 12N CONNECTION 15 AMPS

Use Posi-Taps to make the connections to CAN HI and CAN LO

How Posi-Taps connect.

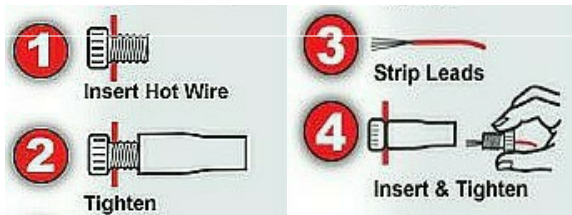

PosiTap connectors

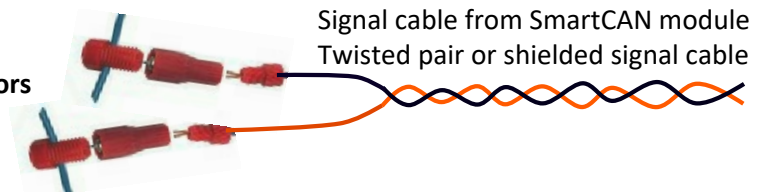

TF2351BMW Kit Components

TF2301
SmartCAN
module

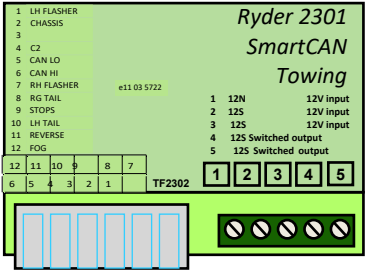

SmartCAN loom
with CANbus Plug

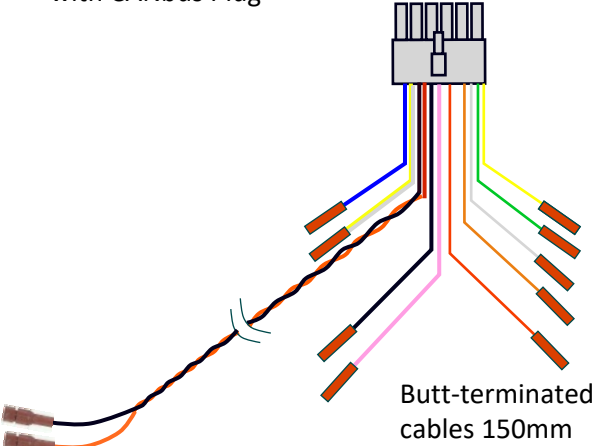

5m twisted pair with
red Posi-Taps

13-Pin kit

- 1 x 13-pin socket assembly, 2 metres
- 1 x Mini buzzer
- 1 x 15 amp mini fuse
- 1 x Black single 28s Aux power cable 1m
- 1 x Red single 35s Aux power cable, 1m
- 2 x PowerTap Mini
- 1 x 20 amp mini fuse
- 3 x OBA blue ring terminals

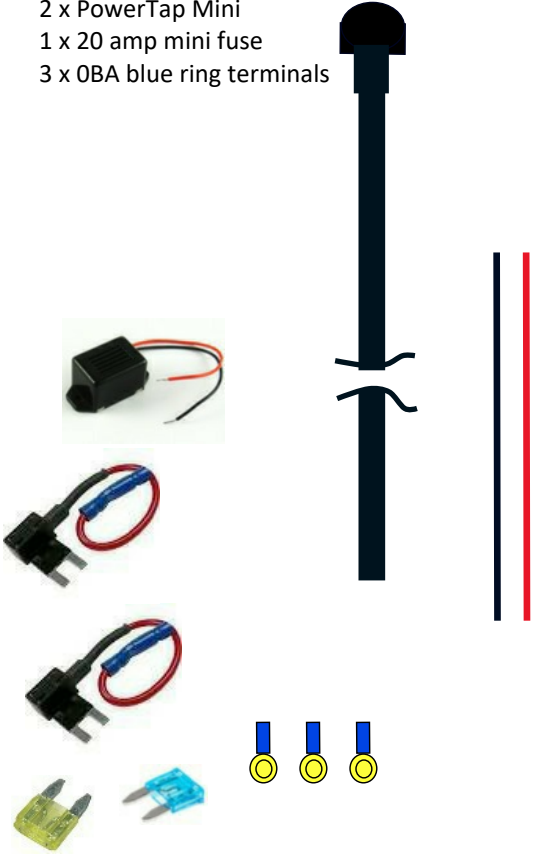

7-pin kit

- 1 x 7-pin socket assembly, 2 metres
- 1 x Mini buzzer
- 1 x Black single 28s Aux power cable 1m
- 1 x PowerTap Mini
- 1 x 15 amp mini fuse
- 1 x OBA blue ring terminal

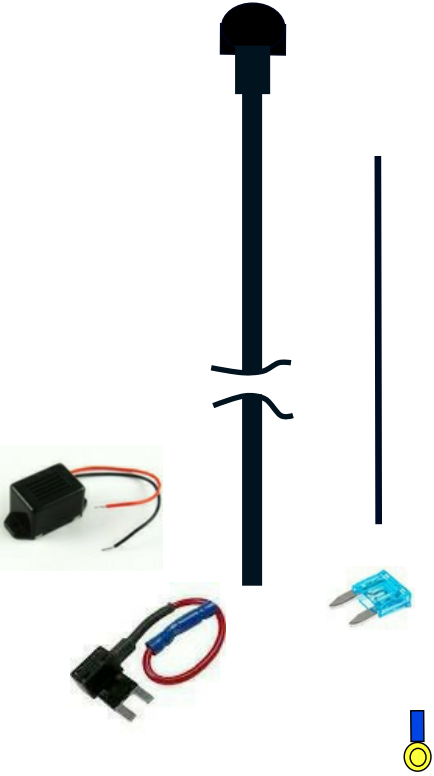

TF2351BMW

CANbus Connections

TF2301 CANbus module

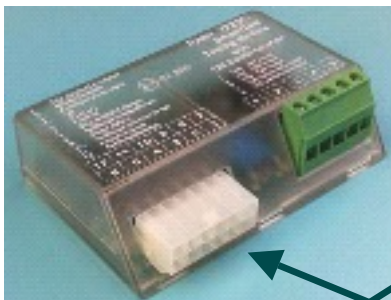

12-pin plug and loom

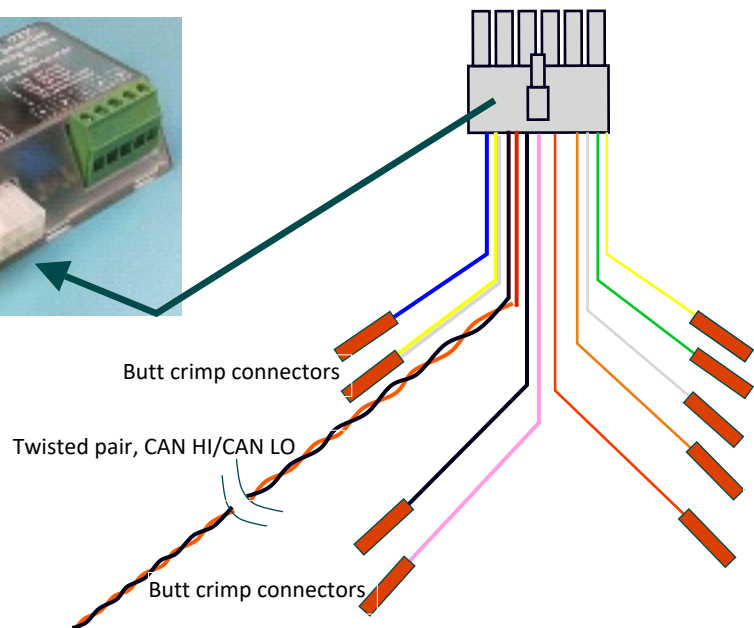

Module loom detail

1	LH FLASHER	YELLOW	Socket yellow 1
2	CHASSIS	WHITE	Ring terminal to chassis
3			
4	C2	PINK	Buzzer
5	CAN LO	BLACK	Twisted pair to CAN
6	CAN HI	RED	
7	RH FLASHER	GREEN	Socket green 4
8	RH TAIL	BROWN	Socket brown 5
9	STOPS	RED	Socket red 6
10	LH TAIL	BLACK	Socket black 7
11	REVERSE	YELLOW/WHITE	13-pin 8 or 12S 1
12	FOG	BLUE	Socket Blue 2

Connections to CAN HI and CAN LO

PosiTap connectors

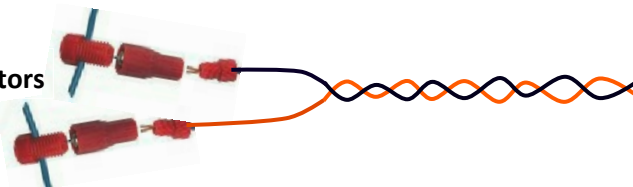

CAN HI and CAN LO: See model specific instructions for CANbus colours.

Or

At OBDII, Pin 3 (HI) and Pin 11 (LO) (Dependent on model).

Socket assemblies

13-pin socket

The orange wire from Pin 9 connects to terminal 3 of the module - unswitched 12S (Interior lights/battery charging)

The grey wire from Pin 10 connects to terminals 4 and 5 of the module - switched 12S (Fridge)

Wires from socket terminals 1 and 2 and 4 to 8 connect to the module plug via the red butt crimp connectors

Overall length of the socket cable is determined by the installation requirements

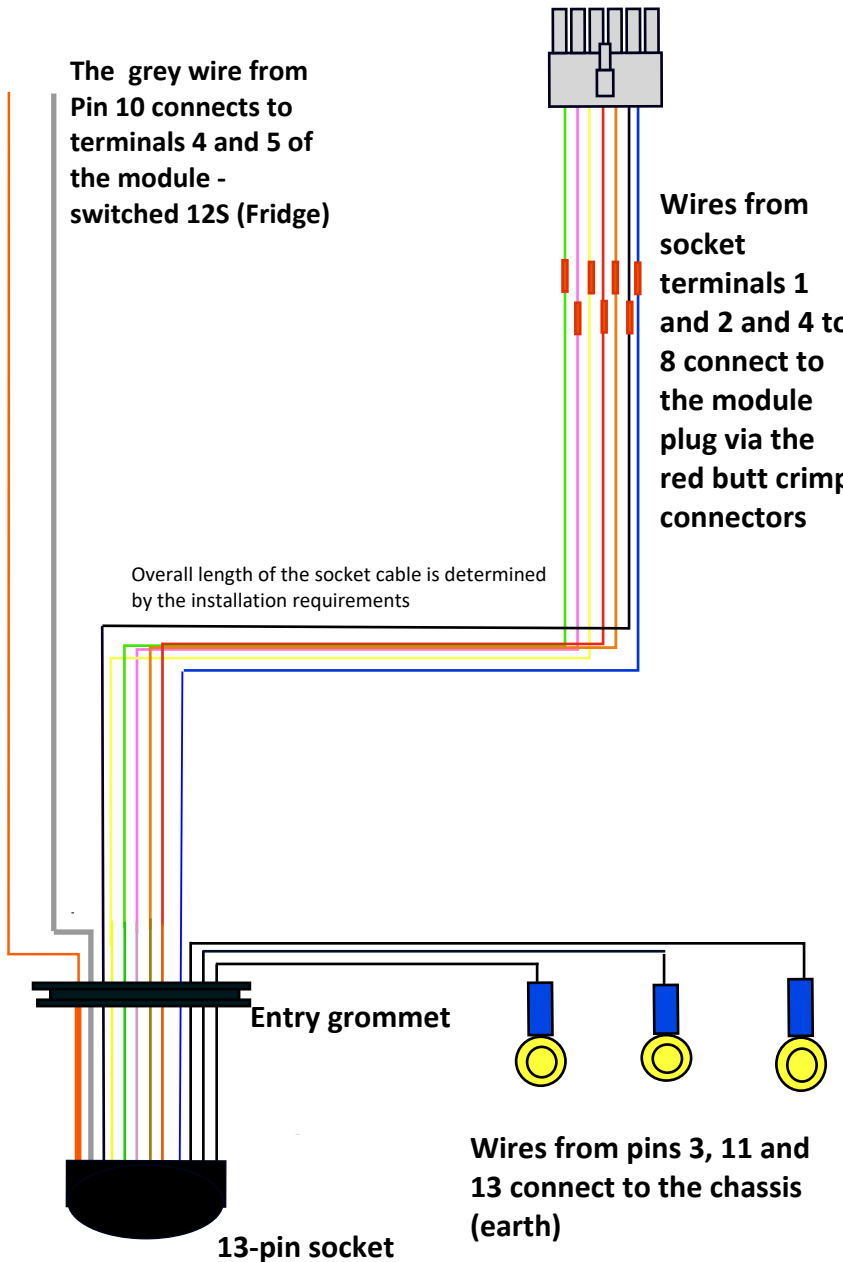

7-pin socket

Wires from socket terminals 1 and 2 and 4 to 7 connect to the module plug via the red butt crimp connectors

Overall length of the socket cable is determined by the installation requirements

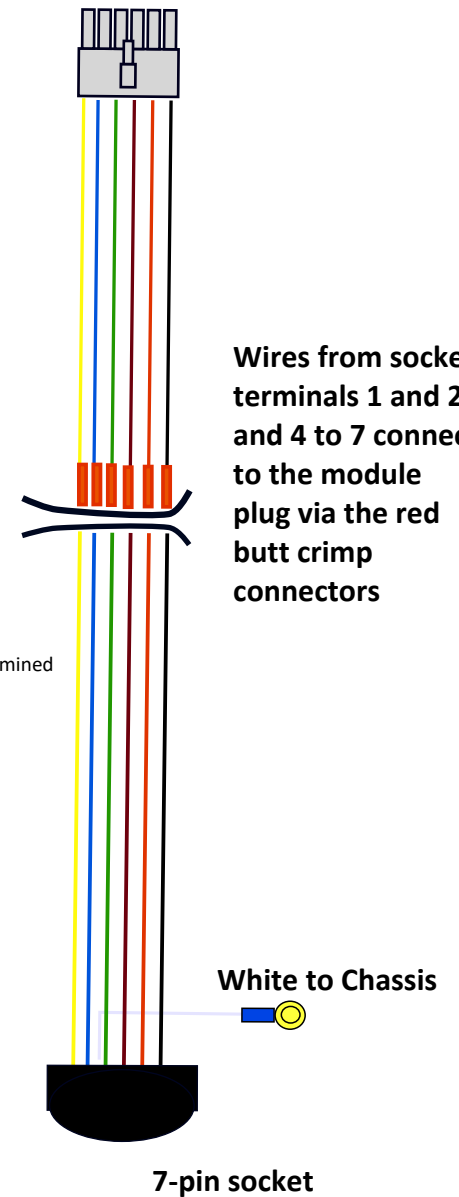

TF2351BMW

Testing and Coding

With the engine both running and at rest, test all functions

Recoding adds C2 on dash; PDC; FCO

or use pink wire from module and a buzzer for C2

(Coding is only required if CAN based C2, Bulb failure monitoring and Trailer present functions are needed.)

(TF2301 SmartCAN unit will provide basic trailer light output, and switched power output without coding)

Ryder Towing

Quality – Service – Innovation

Spimin House, Beacon Road, Poulton-le-Fylde, Lancs, FY6 8JE 01253 881008 www.rydertowing.co.uk mail@rydertowing.co.uk